

Elegant

Trio

GÜNKO INDUSTRIAL

Professional Rack Cabinet For Cost Effective Network Infrastructures

Width: 800mm

Elegant Trio rack series offers the permanent solution for management of Network devices and cables. Unique, flexible and cost effective range is the ideal solution to support the Network and server applications with its durable structure.

Elegant Trio rack networking Cabinet are intended for installation of data and telecommunication devices and their distribution systems, mostly used for structured network cabling systems in Office environments also to be used in computer-rooms and small or large sized data-centers, lot of options for doors, side- and rear panels, as well as many different accessories, make the use of the enclosure very flexible.

Vertical mounting rails are adjustable throughout the entire depth of the cabinet and have very high carrying capacity with 1.5mm thickness Silk-screen mounting rails are providing ability to count U- Marking from top to down & down to up for easy device installation

Removable side and rear panels allow comfortable and easy access to the installed devices for maintenance from all sides of the cabinet, it is possible to install an optional fan-unit into the roof

Width=800mm Elegant Net - Huge IT rack cabinets are designed for housing the Patch panels, switching installation, patch cord / cable management



Front view
With Double Glass door

Side Solid
metal Panel

Rear Solid
metal Panel



Curved type perforated
front door 80%

Splitted rear
Perforated doors 80%



Protect your device against overheating by choosing the right fan module.

We offer a wide product range of ventilation units with the different fan modules.

- On/Off switch
- Analog or digital thermostat control unit Fan modules



M-Joint cable entry panels located on the top cover designed for easy cabling and High-density cabling. Dimensions w: 300 – D: 56 mm x2pcs Left/right



Vertical mounting rails are adjustable throughout the entire depth of the cabinet and have very high carrying capacity with 1.5mm thickness, Silk-screen mounting rails are providing ability to count U-Marking from top to down & down to up for easy device installation



Sliding & M-Joint cable entry panel located on the bottom plates has been designed for easy cabling and Highdensity cabling by using cable entry panels with the dimensions w: 300 – D: 125 mm

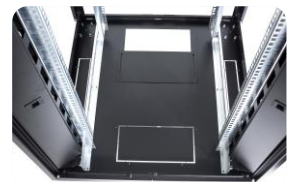

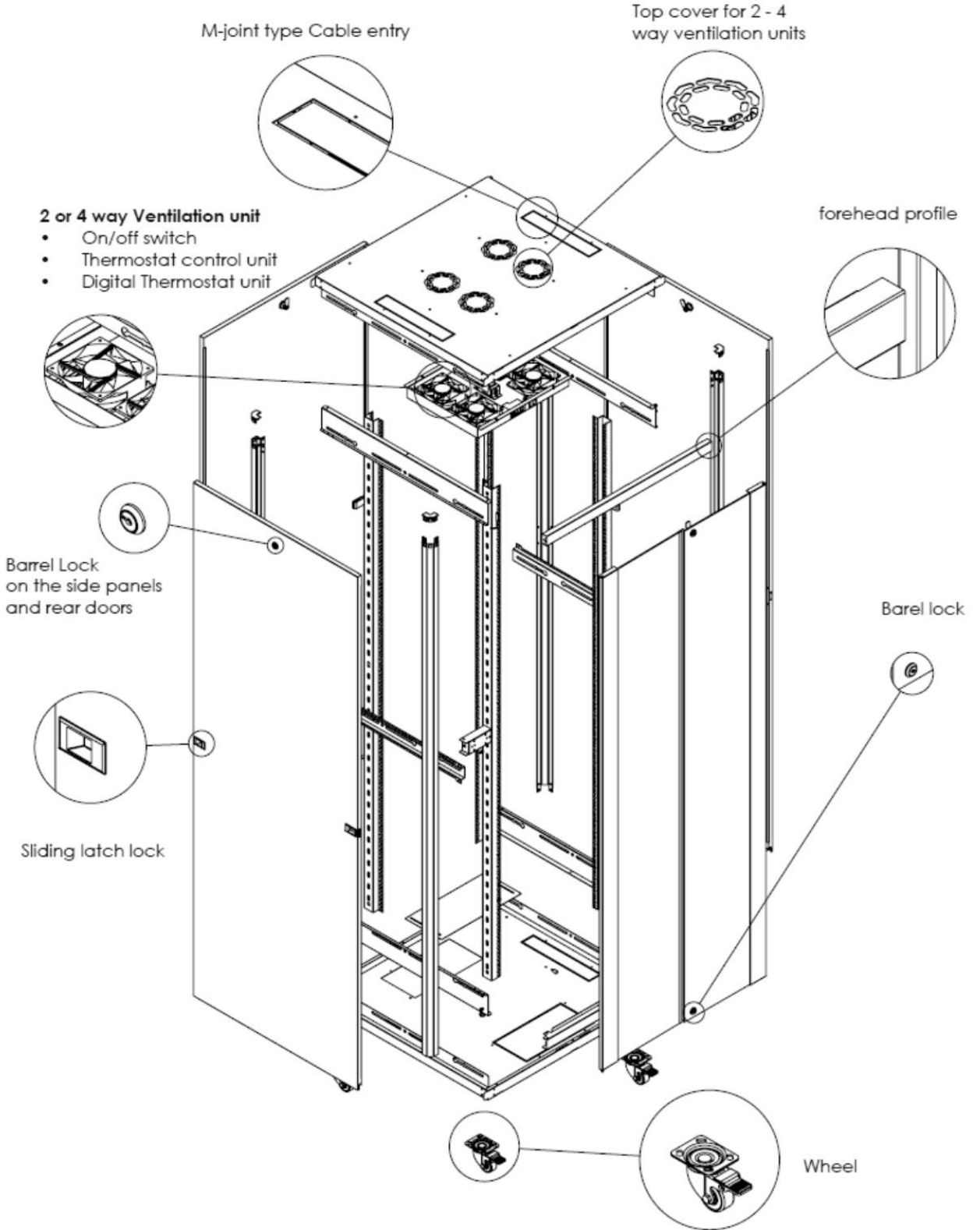

Width: 800mm

Technical Drawings

FRONT VIEW

REAR VIEW

SIDE VIEW

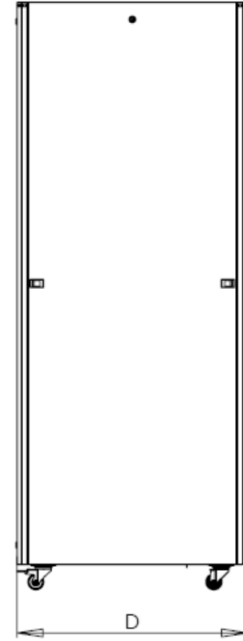
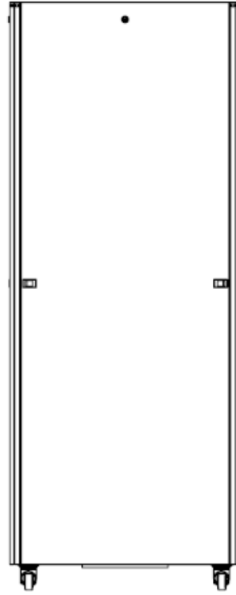
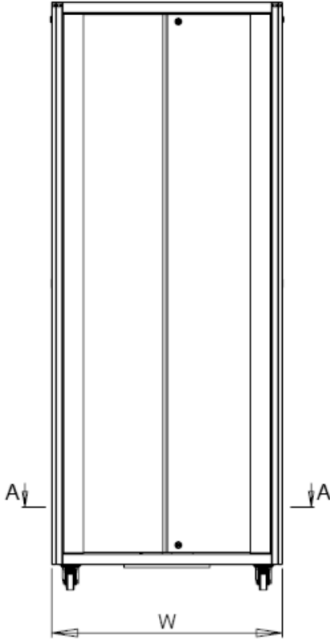

BOTTOM VIEW

TOP VIEW

INNER VIEW

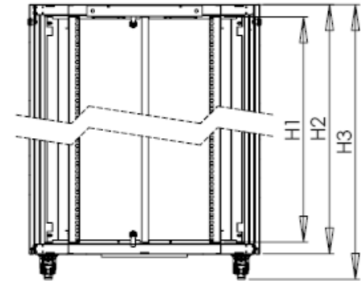
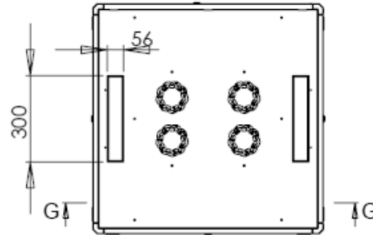
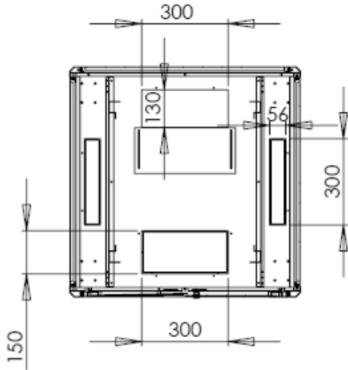

Product code	Product description	Out width (W)	Out depth(D)	H:1 inner Height	H:2 Out Height without feet & wheel set	H:3 Out height with levelling feet	H:4 Out height with wheel set
ELGT 26U 8080 BL 221	Elegant Trio 19" 26U W=800 mm D=800 mm	800	800	1158,9	1243,8	1273,8	1323,8
ELGT 32U 8080 BL 221	Elegant Trio 19" 32U W=800 mm D=800 mm	800	800	1425,6	1510,5	1540,5	1590,5
ELGT 42U 8080 BL 221	Elegant Trio 19" 42U W=800 mm D=800 mm	800	800	1870,1	1955	1985	2035
ELGT 26U 8010 BL 221	Elegant Trio 19" 26U W=800 mm D=1000 mm	800	1000	1158,9	1243,8	1273,8	1323,8
ELGT 42U 8010 BL 221	Elegant Trio 19" 42U W=800 mm D=1000 mm	800	1000	1870,1	1955	1985	2035